



PRODUCTS CATALOG

ELECTRICAL ENCLOSURES & MODULAR CABINETS



20

SCREW COVER SUBMERSIBLE POLYESTER ENCLOSURES

The **5600 ESPLS** are suited for use indoors or outdoors where corrosion is a problem, to protect the enclosed equipment from water coming from any direction, dust, dirt and oil. The 5600 ESPLS is made of a polyester and polycarbonate hybrid blend, aesthetically designed and produced exclusively by EXM. It is the material of choice for numer-

ous industrial applications. Its electrical, chemical and physical properties allow to be used in many environments and for a wide variety of applications. A high quality molded gasket ensures a complete NEMA 6P seal. The cover screws are made of stainless steel. The body of the 5600 ESPLS enclosures incorporates mounting holes. Enclosures

can be completed with an **optional 14 GA galvanized inner panel**, which can be mounted in the rear of the enclosure on the cover. Cover screw inserts can be removed and replaced by quick release latches (see p.384).

**CSA Certified / UL Listed
NEMA/EEMAC 6P / IP68**

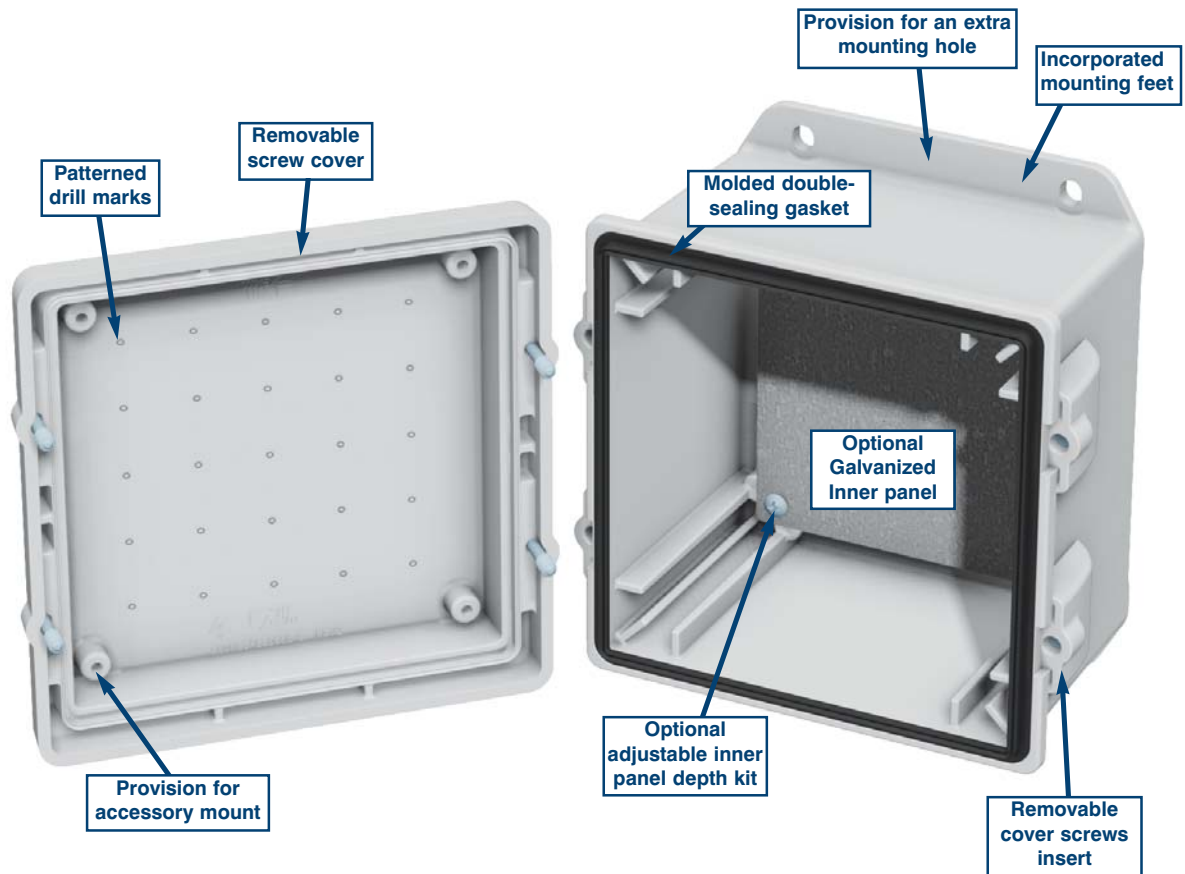

The 5600 ESPLS
Available only from EXM

SCREW COVER SUBMERSIBLE POLYESTER ENCLOSURES

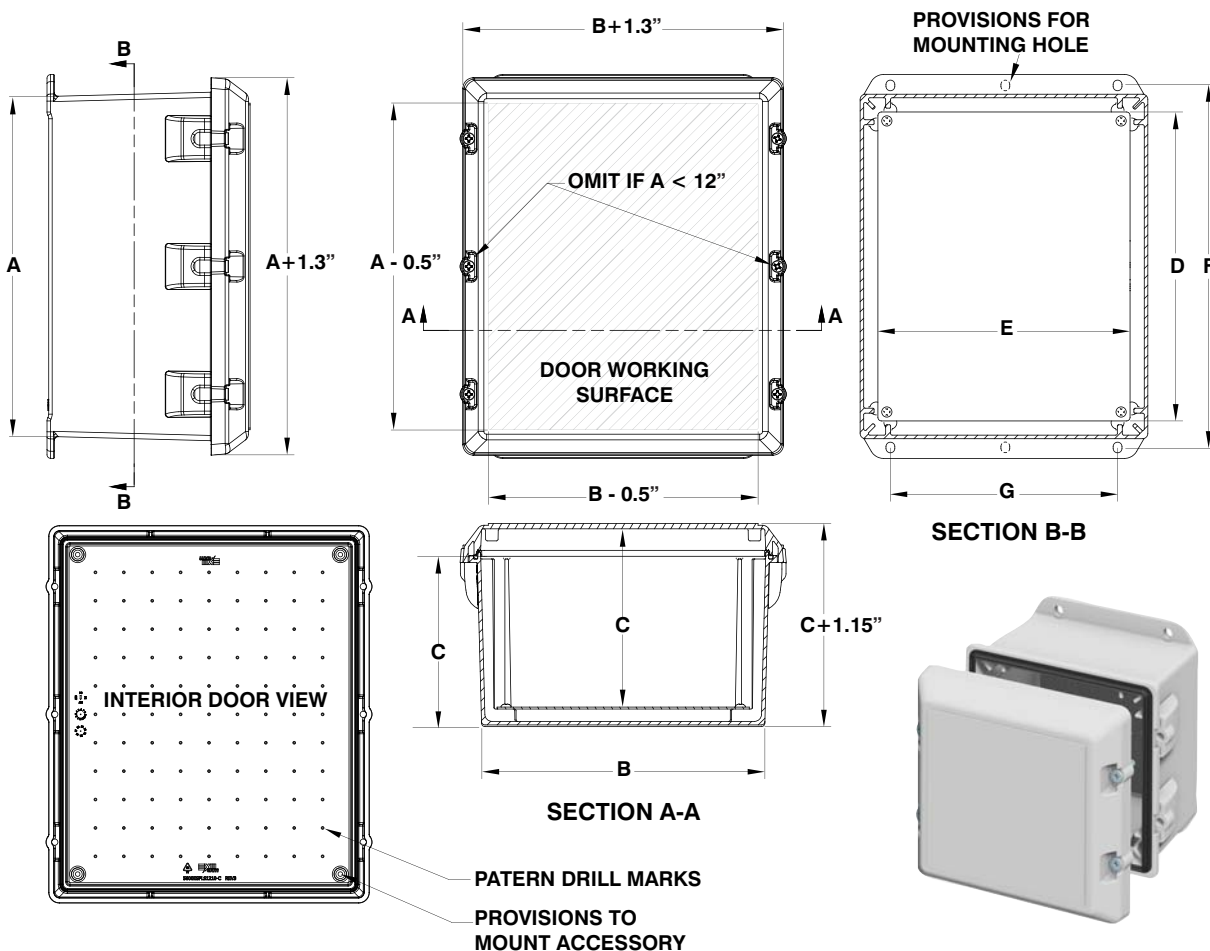

CATALOG NUMBER	DIMENSIONS							EQUIPMENT PANEL FULL	SHIP WGT LBS.
	A	B	C	D	E	F	G		
5600 ESPLS060404	6	4	4	4.88	2.88	7.75	2	880 SP0604G	1
5600 ESPLS060604	6	6	4	4.88	4.88	7.75	4	880 SP0606G	2
5600 ESPLS080604	8	6	4	6.88	4.88	9.75	4	880 SP0806G	2
5600 ESPLS080804	8	8	4	6.88	6.88	9.75	6	880 SP0808G	2
5600 ESPLS100804	10	8	4	8.88	6.88	11.75	6	880 SP1008G	3
5600 ESPLS101006	10	10	6	8.88	8.88	11.75	8	880 SP1010G	4
5600 ESPLS121006	12	10	6	10.88	8.88	13.75	8	880 SP1210G	7
5600 ESPLS141208	14	12	8	12.88	10.88	15.75	10	880 SP1412G	6
5600 ESPLS161408	16	14	8	14.88	12.88	17.75	12	880 SP1614G	10
5600 ESPLS161610	16	16	10	14.88	14.88	17.75	14	880 SP1616G	12

CATALOG NUMBER	METRIC DIMENSIONS							EQUIPMENT PANEL FULL	SHIP WGT KGS.
	A	B	C	D	E	F	G		
5600 ESPLS060404	152	101	101	124	73	197	51	880 SP0604G	0.45
5600 ESPLS060604	152	152	101	124	73	197	102	880 SP0606G	0.91
5600 ESPLS080604	203	152	101	175	124	248	102	880 SP0806G	0.91
5600 ESPLS080804	203	203	101	175	175	248	152	880 SP0808G	0.91
5600 ESPLS100804	254	203	101	226	175	298	152	880 SP1008G	1.36
5600 ESPLS101006	254	254	152	226	226	298	203	880 SP1010G	1.81
5600 ESPLS121006	304	254	152	276	226	349	203	880 SP1210G	3.18
5600 ESPLS141208	356	304	203	327	276	400	254	880 SP1412G	2.72
5600 ESPLS161408	406	356	203	378	327	451	305	880 SP1614G	4.54
5600 ESPLS161610	406	406	254	378	378	451	356	880 SP1616G	5.44